

BAYSTACK ACCESS NODE AND ACCESS NODE HUB

WORKGROUP PRODUCTS BAYSTACK

The Bay Networks BayStack™

Access Node (AN®) and Access Node Hub (ANH™) routers cost-effectively connect small remote offices and ensure network availability while minimizing network operating costs.

Typical connectivity requirements of remote offices are supported by the BayStack AN router's LAN interfaces (Ethernet and Token Ring) and serial interfaces (Synchronous, one T1/FT1 data service unit/channel service unit (DSU/CSU) or 56/64 Kbps DSU/CSU adapter module, and one ISDN Basic Rate Interface (BRI)). The fully managed BayStack ANH supports either eight or twelve 10BASE-T repeater ports, as well as Synchronous interfaces, one or two Synchronous and ISDN BRI interfaces, and one T1/FT1 DSU/CSU or 56/64 Kbps DSU/CSU adapter module, reducing equipment and management complexity.

In all BayStack AN and ANH configurations, the serial interfaces provide remote office network design flexibility. For mission-critical applications, they facilitate Dial Backup and Bandwidth-on-Demand support. In addition, Dial-on-Demand functionality enables a BayStack AN to extend network availability on an as-needed basis to small remote sites, minimizing WAN service costs. Optionally, Synchronous interfaces can be used for Synchronous Data Link Control (SDLC), allowing both IBM SNA and multiprotocol LAN traffic over one consolidated WAN link to the internetwork backbone.

The BayStack AN and ANH easily integrate with the enterprise internetwork by supporting Bay Networks Routing Services (BayRS™), which provides support for all major LAN and WAN protocols. The Motorola MC68360 microprocessor, used in the BayStack AN and ANH router's highly integrated design, easily maintains high forwarding and filtering rates regardless of the number of protocols and network interfaces used—even when processing SNMP management inquiries.



Bay Networks *Where Information Flows.™*

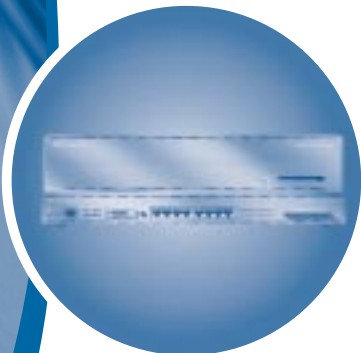

The BayStack AN and ANH are easily configured and monitored via Bay Networks Optivity® family of network management applications. The BayStack AN and ANH also support standards-based RMON tools that ease problem resolution, enhance interoperability, and protect investments. Comprehensive Ethernet RMON support allows remote networks to be monitored from a central location.

The BayStack AN and ANH are critical parts of the BayStack product family. Combined with the BayStack 10BASE-T stackable hubs, 100BASE-T hubs, remote access devices, and Ethernet switches, the BayStack AN and ANH deliver a robust, scalable solution for remote offices and Internet access.

Benefits

Extends Remote Office Connectivity

BayRS supports all major routing and bridging protocols, maximizing connectivity and interoperability in multi-vendor, multiprotocol environments. Additionally, the BayStack AN and ANH consolidate SNA and NetBIOS traffic across the multiprotocol inter-network by supporting Data Link Switching (DLSw) (RFC 1434), the industry standard IBM transport protocol, and the Advanced Peer-to-Peer Networking (APPN). Furthermore, enterprise-wide connectivity is extended to small remote sites through Dial-on-Demand support.

Maintains Network Availability

Uninterrupted remote office network operation is ensured by the Dial Backup feature of the BayStack AN and ANH, which provides a backup link to the backbone if the primary link fails. The BayStack AN and ANH also support dynamic reconfiguration, which allows online software changes to be made without disrupting network operation. Data Compression, Traffic Prioritization, and Uniform Traffic Filters increase available bandwidth and optimize network efficiency. Bandwidth-on-Demand support maintains routing performance by establishing supplemental dial connections if the primary link becomes congested. BayStack AN and ANH support of RMON's remote network monitoring and analysis capabilities enables malfunctions to be viewed and corrected before they cause major problems.

Minimizes Network Operating Costs

BayStack ANH configurations integrate the function of both a router and a hub into one platform, simplifying equipment and management requirements. The EZ Install™ feature reduces installation time and expense by enabling the BayStack AN or ANH to get its IP address and configuration from a central site. Remote site software maintenance time and expense are also minimized by the EZ Update feature of the BayStack AN and ANH, which allows software updates to be downloaded from a central site. Problems at remote sites can also be solved from a remote site via the BayStack AN and ANH routers' standards-based Ethernet RMON RFC 1757 support.

Data Compression support also minimizes costs by enabling lower cost links to achieve the throughput rates of higher cost links. Small remote offices can also connect to the inter-network on an as-needed basis via the BayStack AN and ANH routers' Dial-on-Demand support.

Integrated with BayStack Stackable Ethernet Product Line

Working with other BayStack products such as the 10BASE-T stackable hubs, 100BASE-T hub, Remote Annex™ 2000, and Ethernet switches, the BayStack AN and ANH contribute a key element to one of the industry's most complete, cost-effective, high-performance Ethernet solutions.

Figure 1 | Network Design Options

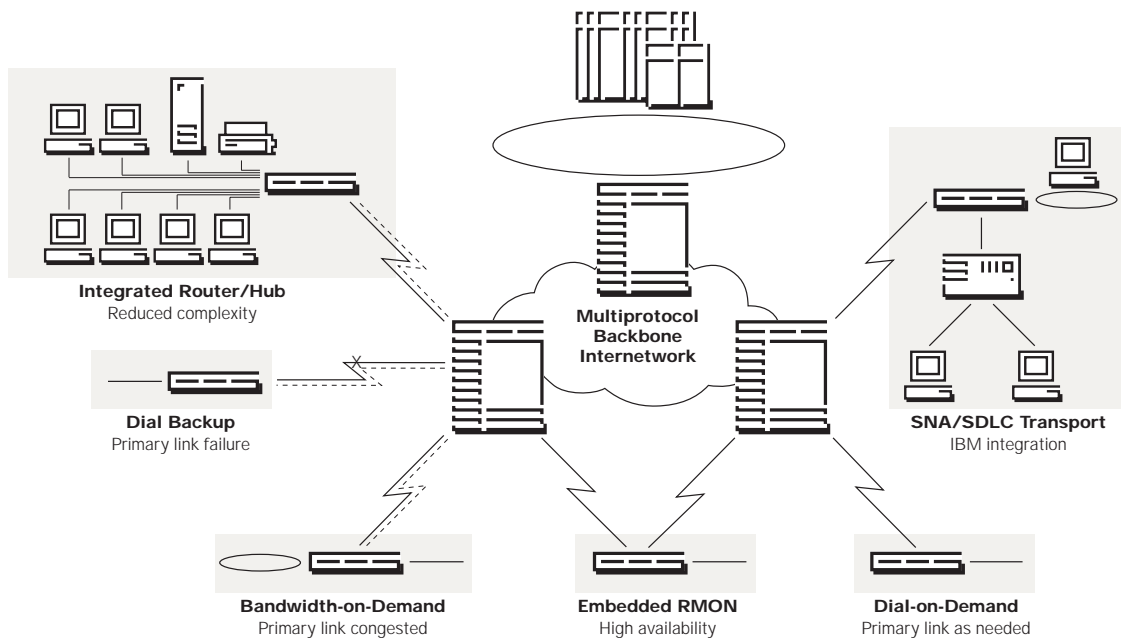

Flexible Network Design

The BayStack AN and ANH meet the connectivity needs of remote offices while providing an extra level of availability. Additionally, the BayStack AN and ANH support SNA/SDLC integration. Multiple network design options are available (see Figure 1).

Dial Backup

Dial Backup maintains remote office connectivity if the primary remote-to-central site link (leased line or packet switched service) fails. The BayStack AN and ANH initiate, monitor, and terminate dial backup connections to maximize network availability, while minimizing dial-up charges.

Bandwidth-on-Demand

Bandwidth-on-Demand provides a supplemental dial connection if the primary link becomes congested, maintaining user-required performance levels.

Dial-on-Demand

Because of the limited amount of internetwork traffic generated by small remote offices, maintaining dedicated links to such sites is not always cost-effective. Dial-on-Demand cost-effectively extends internetwork connectivity to remote offices on an as-needed basis.

SDLC Transport

SDLC transport enables the BayStack AN and ANH to transmit SNA/SDLC traffic across a multiprotocol backbone via standards-based DLSw for SDLC or Transparent Synchronous Pass-Through features. These features reduce the cost of wide area networks by consolidating parallel lines, allowing SDLC traffic to be sent across the multiprotocol backbone to a remote IBM host.

Integrated Router-Hub Connectivity

The integrated Ethernet hub configurations allow the BayStack ANH to manage and connect eight or twelve 10BASE-T remote workgroup resources directly to a central site via leased line and/or packet switched services.

Remote Monitoring (RMON) Option

The BayStack AN and ANH support an optional integrated Data Collection Module (DCM), which provides standard RMON (RFC 1757—all nine groups) probe capabilities plus real-time packet capture and filtering. Using a dedicated 25 MHz Motorola MC68040 microprocessor and 2 MB DRAM, the DCM continuously monitors the Ethernet segment of the BayStack AN or ANH, collecting data to be used in analyzing remote network performance, topology, faults, departmental usage (for accounting purposes), and protocols.

Bay Networks Optivity Planning™ and Optivity Analysis™ network management applications deliver full RMON support. These applications enhance strategic network planning by collecting, correlating, and summarizing long-term performance data. Historical information on network activity can be used to detect trends in network performance and to recommend optimum network configuration.

Third Synchronous, ISDN BRI, Second Ethernet, T1/Fractional T1 (FT1) DSU/CSU or 56/64 Kbps DSU/CSU Option

In addition to the two standard Synchronous interfaces, the BayStack AN and ANH can be configured, either at the factory or as a field upgrade, with an optional third Synchronous, ISDN BRI, T1/FT1 DSU/CSU or 56/64 Kbps DSU/CSU adapter module. If an ISDN BRI port configured with two B channels and one D channel is enabled, only one synchronous port (COM2) is active.

With these modules, the BayStack AN and ANH routers can provide a single-platform solution for applications requiring a primary link, backup link, and Synchronous interface for legacy (SDLC, X.25, Binary Synchronous Communications (BSC)) integration. Additionally, Ethernet BayStack AN and ANH systems support a second Ethernet interface. With two Ethernets, the BayStack AN and ANH can provide shared WAN access to two workgroups that require the firewall security of operating on separate LANs.

Hardware Features

LAN and Serial Interfaces

The Bay Networks BayStack AN supports Ethernet and/or Token Ring, and Synchronous and ISDN BRI interfaces to meet a wide variety of LAN connectivity requirements.

The third Synchronous interface, second Ethernet interface, and ISDN BRI of the BayStack AN and ANH are provided via optional adapter modules. If an ISDN BRI port configured with two B channels and one D channel is enabled, only one synchronous port (COM2) is active. These modules can be easily removed or exchanged to meet changes in network requirements for enhanced flexibility and connectivity.

Ethernet/802.3 All Ethernet/802.3 interfaces support IEEE 802.3 and Version 1.0/2.0 Ethernet frame formats. Ethernet/802.3 models (single and dual Ethernet, single Ethernet with single Token Ring) are available in configurations that provide one 10BASE-T (RJ-45) connector and one Attachment Unit Interface (AUI) connector for a choice of connectivity. A cable from the interface's 15-pin AUI connector provides optional connec-

tors to a variety of media, including broadband, baseband, Starlan, fiber, and shielded twisted pair. This flexibility accommodates the media that best suits distance, cost, and reliability criteria.

Ethernet Hub The BayStack AN Ethernet/802.3 models are also available with an integrated 10BASE-T hub configuration.

The BayStack ANH simplifies remote site equipment requirements and management by integrating Ethernet connectivity with routing services in the BayStack AN.

The BayStack ANH provides 8 or 12 managed 10BASE-T (RJ-45) repeater ports for shielded or unshielded twisted pair cable attachment. Each connector is configured as an Medium Dependent Interface with internal crossover (MDI-X) to connect directly to any 10BASE-T network interface card (NIC). BayStack ANH models can also be configured as a Medium Dependent Interface (MDI) to allow the BayStack ANH to be connected to other 10BASE-T hubs, accommodating additional devices. An optional second Ethernet adapter module is available for both 8- and 12-port BayStack ANH models. Router/hub LEDs report per-port link integrity status and port partitioning status, as well as the MDI/MDI-X switch setting.

Token Ring/802.5 The Token Ring interface can operate at either 4 or 16 Mbps ring speeds (software configurable), providing the flexibility to migrate to higher speeds as performance requirements dictate. A 9-pin D subminiature connector is provided on the Token Ring BayStack AN models for Token Ring cable attachment.

The Token Ring interface also sup-

ports the IEEE 802.5 Media Access Control (MAC) token passing protocol, the 802.2 Type 1 (connectionless) protocol, the 802.2 Type 2 (connection-oriented) protocol, and the 16 Mbps Early Token Release (ETR) protocol.

Synchronous The Synchronous interfaces support V.35, RS-232, RS-449/422 balanced, and X.21. Each Synchronous interface operates from 1,200 bps to 2.048 Mbps, full duplex, allowing use of lines up to T1 and E1 rates. Internal and external clocking, as well as all major wide area networking protocols, are supported by the Synchronous interfaces.

Alternatively, the Synchronous interfaces can be configured to integrate IBM SDLC traffic across the internet-work by connecting local or remote IBM equipment directly to the Synchronous interface and using either integrated DLSw for SDLC or Transparent Synchronous Pass-Through. PU Type 2.0 and 2.1

devices are supported to provide a highly flexible interconnection solution. The Synchronous interfaces support connection to these devices using a V.24 (RS-232), V.35, or X.21 physical interface. Additionally, the Synchronous interfaces ensure optimum SDLC performance by supporting numerous SDLC parameters (see Table 1).

ISDN Basic Rate Interface (BRI)

The BayStack AN ISDN BRI option provides two 64 kilobit-per-second (Kbps) B channels for data and one 16 Kbps D channel for signaling. The ISDN BRI feature supports many signaling specifications (see Table 2). This feature is supported on the single Ethernet, single Token Ring, and Ethernet/Token Ring BayStack AN router, and the BayStack ANH router/hub models. If an ISDN BRI port configured with two B channels and one D channel is enabled, only one synchronous port (COM2) is active.

T1/Fractional T1 (FT1) Data Service Unit/Channel Service Unit (DSU/CSU)

The T1 and FT1 DSU/CSU module offers high-speed connectivity to the digital services networks in North America. It is capable of operating at fractional T1 rates, in increments of 64 Kbps, up to 1.544 Mbps. Users can customize the DS-0s in the FT1 connection. For example, users can select DS-0 # 1, 5, 15, and 18 to make up a 256 Kbps fractional T1 link. This module is designed to support one logical channel per one physical interface, typical of a remote branch office requirement. Extensive diagnostic and test functions, such as loopbacks and bit error rate test (BERT) tests, are also built in for easy troubleshooting.

E1/Fractional E1 Adapter Module

The E1 and Fractional E1 (FE1) adapter module provides a 2.048 Mbps G.703 interface for high-density access to a variety of international communications services.

Table 1 | SDLC Parameters

Parameter	Function
NRZ/NRZI	Specifies line support: Non-return to Zero or Non-return to Zero Inverted.
Half/Full-Duplex	Specifies how server communicates with downstream PU.
Constant/Switched	Specifies how server controls Carrier Request To Send signal to a modem.
Transmit Clocking	Specifies transmit clocking type: Internal or External.

Table 2 | Supported ISDN Signaling Specifications

Region/Country	ISDN Standard
Australia	AUSTEL TS013
Europe	Euro ISDN (CTR 4)
France	VN-3
Japan	INS-64
North America	National ISDN-1, AT&T 5ESS, Northern Telecom DMS-100

Figure 2 | 2-Port Access Node Router/Hub Connector Panel

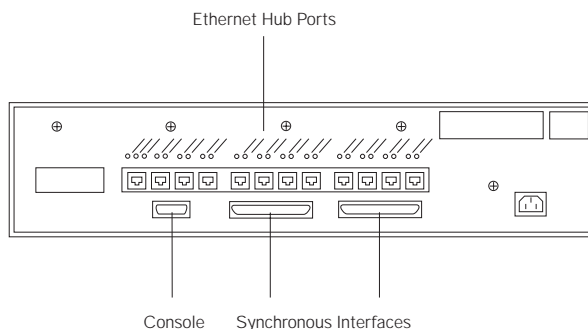

56/64 Kbps DSU/CSU The integral 56/64 Kbps DSU/CSU adapter module provides direct synchronous access to either 56 Kbps Dataphone Digital Service (DDS) or 64 Kbps Clear Channel dedicated services, facilitating a simpler connection between the router and the service provider's facilities.

Extensive diagnostic and loopback test capabilities, including the generation of and response to ITU-T V.54 Remote Loopback, allows network administrators to readily pinpoint WAN connection difficulties with either router, DSU, or WAN facilities, making the router easier to troubleshoot.

High-Performance Processor

The BayStack AN and ANH, incorporating Motorola's 68360 microprocessor, maintain high forwarding and filtering rates across BayStack AN and ANH network interfaces. Additionally, management inquiries are processed without affecting performance. The BayStack AN and ANH support 8 or 16 megabytes (MB) of DRAM, which is configurable to support customized partitioning between local and global

memory. Router software resides in local memory, while global memory is dedicated to packet buffers. Through these reserved buffers, the BayStack AN and ANH prevent traffic overflow—and resulting network delays—caused by large bursts of traffic (e.g., file transfer operations).

The BayStack AN and ANH support a 4 or 8 MB standard Personal Computer Memory Card International Association (PCMCIA) Flash memory card for nonvolatile storage of the system software and configuration file, and event log. To provide redundancy, the PCMCIA Flash can be logically divided into two partitions of equal card size. Each partition is a uniquely addressable and fully functional Flash file system volume. Copies of boot images and configuration files can be stored on each partition.

Packaging and Power Options

The BayStack AN routers and the BayStack ANH router/hubs require minimal space and are quiet and compact (see Figure 2). Both can operate in either a wiring closet or desktop environment and are rack or wall mountable. LEDs indicate module status for easy troubleshooting.

The BayStack AN, 8-port BayStack ANH, and 12-port BayStack ANH are available with one 100 to 240 VAC power supply. The Ethernet-based BayStack AN and 8-port BayStack ANH are also available with one -48 VDC to -60 VDC power supply.

Software Features

Bay Networks Routing Services (BayRS)

The BayStack AN and ANH, with support for BayRS, maximize remote office connectivity in multivendor, multiprotocol environments by supporting all major network and bridging protocols. Industry-standard IBM transport is also supported via the Bay Networks router's DLSw and APPN support to maintain remote office availability.

Software Options Three BayRS software options are available for the BayStack AN and ANH—IP Access, Remote Office, and Corporate (see Table 3). This allows the BayStack AN and ANH to be configured with software that fits a site's requirements.

Table 3 | Bay Networks Routing Services for BayStack AN and ANH

Feature	IP Access	Remote Office	Corporate
Network Protocols			
IP	✓	✓	✓
Novell IPX		✓	✓
AppleTalk Phase 2		✓	✓
OSI			✓
DECnet Phase IV			✓
Banyan VINES			✓
Xerox XNS			✓
ST-II	✓	✓	✓
IBM Integration			
Source Route Bridge	✓	✓	✓
LAN Network Manager Agent		✓	✓
Data Link Switching for Ethernet and Token Ring		✓	✓
Data Link Switching for SDLC		✓	✓
Transparent Synchronous Pass-Through	✓	✓	✓
APPN			✓
Bridging			
Transparent (Ethernet)	✓	✓	✓
Translation Bridge Ethernet			
Token Ring	✓	✓	✓
Native Mode LAN (NML)	✓	✓	✓
Wide Area Networking			
HDLC Encapsulation	✓	✓	✓
Point-to-Point Protocol (PPP)	✓	✓	✓
Frame Relay	✓	✓	✓
ISDN BRI	✓	✓	✓
SMDS	✓	✓	✓
X.25	✓	✓	✓
ATM DXI	✓	✓	✓
Dial Backup	✓	✓	✓
Bandwidth-on-Demand	✓	✓	✓
Dial-on-Demand	✓	✓	✓
Traffic Management			
Data Compression	✓	✓	✓
Traffic Prioritization	✓	✓	✓
Uniform Traffic Filters	✓	✓	✓
Node Management			
EZ Install/EZ Update	✓	✓	✓
Dynamic Loader	✓	✓	✓
RMON	✓	✓	✓

Traffic Management

Comprehensive traffic management capabilities are provided through Data Compression, Traffic Prioritization, and Uniform Traffic Filters.

Data Compression Configurable on a per-circuit or link basis, the Bay Networks software-based Data Compression feature is supported by all Bay Networks routers, maximizing internetwork performance by reducing the amount of bandwidth required to transport LAN protocols over the wide area. Data Compression is currently supported over Frame Relay, X.25, and Point-to-Point (PPP) (dial-up lines, including ISDN, and leased lines). Based on a Lempel-Ziv algorithm, Bay Networks payload compression mechanism provides an aggregate compressed throughput over BayStack AN and ANH full-duplex serial links at speeds of up to 128 Kbps.

Traffic Prioritization Traffic Prioritization filters can assign a high priority to time-sensitive and/or mission-critical traffic, thereby reducing the occurrence of session timeouts and improving application response times. Priority filters can be configured to place packets into one of three priority queues—high, normal, or low—for transmission through a

Bay Networks router's outbound serial interface. Priority filters can be applied to the complete family of network and bridging protocols supported by Bay Networks routers.

Priorities can be assigned to packets based on their protocol, source network, destination network, packet type, and other protocol-specific fields, as well as other fields that are identifiable by an offset in a packet.

Traffic Prioritization can be configured to use either a strict dequeuing algorithm or a bandwidth allocation dequeuing algorithm to transmit packets across a serial line. Bay Networks strict dequeuing algorithm transmits all packets from the high-priority queue before transmitting packets from the normal and low-priority queues. The bandwidth allocation dequeuing algorithm ensures that large amounts of high-priority traffic do not prevent transmission of other traffic, based on user-assigned bandwidth allocation percentages for each queue.

Uniform Traffic Filters Uniform Traffic Filters enables inbound and outbound traffic filters to be easily established for all network and bridge protocol traffic. Uniform Traffic Filters provides an efficient method for developing an effective and comprehensive network security strategy. In addition, Uniform Traffic Filters preserves WAN bandwidth and can increase performance by reducing network congestion.

Inbound traffic filters can be configured to accept or drop incoming packets from any Bay Networks router's local area, ATM, or serial network interface. Outbound traffic filters can be configured to drop outgoing packets destined for any Bay Networks router's serial interface.

Filters can be created using predefined protocol-specific fields or user-defined fields. Uniform Traffic Filters can be configured to accept or drop a packet when a packet's field matches the values defined in the filter. Additionally, such packet/filter matches can be logged. Up to 31 inbound filters and 31 outbound filters (including Traffic Prioritization filters) can be defined for each protocol on every supported network interface. Filter precedence can be configured on an interface, reducing filter definition complexity. All filters are configured via Site Manager, the node management application for Bay Networks routers.

Remote Installation and Management

EZ Install and EZ Update simplify BayStack AN and ANH installation and make router reconfiguration and software updates from a central site quick and easy. Additionally, standard RMON features are provided by the RMON Data Collection Module (DCM) in the 8-port BayStack ANH for analyzing remote network attributes.

EZ Install EZ Install eliminates the time and expense of sending a technical resource to install and configure a BayStack AN. All that is required at the remote site is connecting the BayStack AN LAN and serial interfaces, and turning on the power. With EZ Install, the BayStack AN obtains its software image from Flash memory and its configuration file through the network. Using EZ Install, the BayStack AN automatically obtains its IP address from a central-site Bay Networks router and its configuration file from a central-site server using the BootP protocol. After verifying that a BayStack AN configuration file has been successfully downloaded to DRAM via EZ Install, the unit's configuration file can be saved to Flash memory for non-volatile local storage.

EZ Update Bay Networks EZ Update facilitates the automatic downloading of software updates and configuration files, minimizing the time and expense associated with remote site software maintenance. The existing BayStack AN configuration file and software image are stored in the nonvolatile Flash memory of the BayStack AN for use as backup in case problems are encountered while downloading new software. To use EZ Update, the BayStack AN is

dynamically configured to boot its configuration file and software image from the central site. The BayStack AN can then be rebooted or power-cycled, and a new configuration file and/or software image will be downloaded to the DRAM of the BayStack AN from a central site server. Once it has been determined that the new configuration file or software update is acceptable, it can be saved to the Flash memory of the BayStack AN, replacing the previous configuration file and/or software image.

RMON Data Collection Module (DCM) Option Ethernet BayStack AN and 8-port BayStack ANH models support an optional integrated remote monitoring (RMON) Data Collection Module. The RMON DCM attaches directly to the processor module of the BayStack AN and ANH.

Each DCM includes a 25 MHz Motorola MC68040 microprocessor and 2 MB DRAM memory. The RMON DCM provides standard Ethernet RMON (RFC 1757—all nine groups) capabilities and real-time packet capture and filtering. The Ethernet segment of the BayStack AN or 8-port BayStack ANH is continuously monitored by the RMON DCM, collecting data to be used in analyzing remote network performance, topology, faults, departmental usage (for accounting purposes), and protocols. One RMON DCM is supported per BayStack AN or 8-port BayStack ANH.

Software Encryption

Bay Networks routers allow sensitive traffic to be protected as it passes across dedicated or dial-up links using PPP. This feature provides confidentiality, authentication, and integrity services to prevent unauthorized disclosure or modification of PPP payloads sent between Bay Networks routers.

Software encryption uses the industry-standard Data Encryption Standard (DES) to encrypt PPP or Frame Relay payloads prior to transmission and to decrypt them on reception. The DES algorithm, in conjunction with user-selected secret keys, provides a high degree of security and is used by financial institutions and governments around the world to protect valuable or sensitive data.

Encryption can be enabled on any Bay Networks router serial interface that currently supports data compression. Encryption can be specified on an interface, line, or circuit basis using Site Manager, which is also used to configure automated key management features.

Software encryption is a standard feature and includes support for 40-bit length DES keys. A separate software option that adds support for 56-bit DES keys is also available.

SNMP-Based Node Management

Bay Networks offers a complete SNMP-based, enterprise management solution for any environment. As members of Bay Networks Optivity Enterprise™ family of network management products, UNIX-based Optivity Internetwork™, and Windows-based EZ Internetwork™ are powerful tools for providing comprehensive UNIX-based or Windows-based router configuration, monitoring, and control. Bay Networks Optivity Planning and Optivity Analysis enhance these powerful management solutions by delivering standards-based RMON tools and providing numerous design, monitoring, and troubleshooting features. The BayStack AN and ANH also support the Technician Interface that further eases configuration and maintenance tasks.

In addition, Bay Networks Online Dynamic Reconfiguration, and Dynamic Software Builder and Loader features reduce router memory requirements and enable remote sites to be configured quickly and easily without disrupting network operations.

The BayStack ANH also supports RFC 1516—the Standard Internet Engineering Task Force (IETF) Definitions of Managed Objects for IEEE 802.3 Repeater Devices, allowing a remote management station to monitor statistics and operational status of each hub port.

Optivity Internetwork A component of Bay Networks UNIX-based Optivity Enterprise application suite, Optivity Internetwork provides a sophisticated, yet easy-to-use management solution for complex router-based internetworks. Optivity Internetwork simplifies and improves management of complex router internetworks by integrating ControlCenter, the revision control system for Bay Networks routers; Site Manager, the node management application for Bay Networks routers; RouterMan™, an intuitive router monitoring application; and PathMan™, a graphical network diagnostic tool.

Optivity Internetwork operates with the leading SNMP platforms—HP OpenView, Tivoli NetView for AIX, and Sun Microsystems's Solstice Domain Manager for additional capabilities.

EZ Internetwork A component of the DOS/Windows-based Optivity Workgroup™ application suite, EZ Internetwork provides a comprehensive set of network management capabilities accessible through a point-and-click, Windows-based user interface for the Bay Networks Access Stack Node (ASN™), BayStack AN, and BayStack ANH routers. EZ Internetwork features an RMON Summary application that provides both graphical and table views of critical statistics for the selected device or LAN segment, including data from the RMON statistics, history, and hosts groups. With RMON Summary, network segment information, such as utilization rates, packet size distribution, packet type statistics, and RMON host table information can be viewed quickly.

Optivity Analysis Part of the Bay Networks Optivity Enterprise family of network management applications, Optivity Analysis provides RMON tools that deliver full RMON support, including support for an industry first—Layer 3 traffic monitoring. The RMON tools of Optivity Analysis provide a powerful means to monitor and analyze the enterprise network leveraging embedded RMON. The Traffic Matrix display gives MAC or Network Layer traffic statistics. By providing Network Layer (OSI Layer 3) traffic monitoring, Optivity Analysis gives powerful insights into traffic across routers. Key Token Ring Source Route Bridging statistics can also be monitored. Furthermore, RMON agent-based alarms and events can be set up either manually, or through an automated enterprise baselining and learning tool.

Optivity Planning Another part of the Optivity Enterprise family consists of DesignMan™, a powerful graphics-based network design tool for planning network segmentation, and NetReporter™, an easy-to-use application that collects data from RMON probes and automatically generates graphical and tabular reports on network performance.

NetReporter allows a network manager to quantify and analyze the behavior of the enterprise network over time. By retrieving real-time data from RMON probes, a high-level view is provided, which can be configured to display all segments simultaneously or a subset of designated LANs. NetReporter automatically generates a variety of predefined or user-defined reports in tabular or graphical formats. Reports can be generated for weekly, monthly, quarterly, or annual reports, and data gathered by multiple collectors can be combined to deliver a single, consolidated report.

Network managers can track key performance characteristics, including utilization, errors, protocol mix, and end-to-end conversations by analyzing changes in resource use over time. This data can be used for planning network reconfigurations and expansions to provide more efficient resource utilization. All data is Structured Query Language (SQL)-accessible, enabling the use of the NetReporter advanced GUI or database management systems (DBMS) for report generation.

Technician Interface This terminal-based (TTY-compatible) tool enables basic configuration and maintenance locally or through Telnet. The Technician Interface is based on a simple command line interpreter that supports SNMP-based access to the Management Information Base (MIB), displays the

event log, and supports file system management and other administrative commands. The Technician Interface also supports out-of-band access to the BayStack AN and ANH through a modem connection.

Bay Command Console (BCC™) This terminal-based (TTY-compatible) tool simplifies local or remote platform installation and maintenance. It is accessed through a directly attached terminal or PC running terminal emulation software or a Telnet session. With BCC, the BayStack AN and ANH provide easy-to-use command line syntax for router configuration and maintenance. It is ideal for centralized management of remote routers.

Online Dynamic Reconfiguration Dynamic reconfiguration eliminates the need to schedule network downtime to reconfigure any BayStack AN or ANH. Configuration parameters can be changed by issuing SNMP SET commands while the switch is operational. Any changes made with SNMP SET are volatile and are lost when the router reboots. To preserve changes, the router's active configuration must be saved permanently to a file in nonvolatile memory. This file defines the router's new baseline configuration and ensures that it is properly configured to meet the current network requirements.

Dynamic Software Builder and Loader

Site Manager's Software Builder works with the Dynamic Loader of the BayStack AN and ANH to preserve the routers' Flash memory and DRAM space. The Software Builder allows software images to be customized. Only required software functionality is maintained in the remote router's software image. For example, if a remote site requires only IP and IPX support, other network protocols can be deleted from the software image to preserve Flash memory space. The Dynamic Loader feature preserves DRAM space by loading to DRAM only the routing functionality that is required by a particular BayStack AN or ANH configuration. Using the previous example, if a particular branch office does not require IPX support, then Dynamic Loader will load only IP to DRAM rather than the complete software image of the BayStack AN.

Managed Hub Support

Complying with RFC 1516, both ANH configurations support SNMP GET and SET management for the monitoring and configuration of individual hub port statistics and operational status information. In addition, the BayStack ANH provides automatic port partitioning to prevent a faulty hub port from affecting the rest of the network. When excessive collisions on an individual hub port are detected, this feature "detaches" the problematic endstation. This allows packets to be transmitted to the endstation but does not permit the hub port to accept packets sent from the endstation. Once packet collisions are no longer sensed, the hub port is automatically returned to normal operation.

Redundant Network Interfaces

Bay Networks LAN interfaces can be configured for 1-for-1 redundancy, allowing two similar LAN interfaces in the same router to be attached to a single LAN. One of the interfaces is designated primary and is fully operational while the other is in a non-operational backup mode. If the primary interface fails, the backup interface becomes operational, ensuring continued availability. IP, IPX, and Source Route Bridging are supported by this feature.

Ethernet interfaces support a Hot Standby feature, which enables a backup interface to become operational very quickly. A Hot Standby interface in backup mode collects network information and uses it to route traffic in the event of a primary interface failure. The Hot Standby feature is intended for use on stub networks.

Redundant Router Support

The routers support a redundant router capability that provides protection against catastrophic events, such as fire or flood, which may eliminate any single router. In Router Redundancy, two identical routers are used. To apply router redundancy, one of the routers is placed in Primary mode and the other in Backup mode. If the primary router fails, the backup will become active and resume routing traffic. IP, IPX, and Source Route Bridge are supported by this feature.

Specifications

Technical specifications for the BayStack AN and ANH appear in Table 4.

Table 4 | BayStack AN and ANH Specifications

Architecture	Single-board module based on Motorola MC68360 microprocessor
Connectivity	Ethernet interface (15-pin AUI connector, RJ-45) Token Ring interface (9-pin MAU connector) Synchronous interface (RS-449/422, RS-232, V.28, V.35, X.21) ISDN BRI (RJ-45) E1/FE1 Adapter Module (RJ-45) E1/FE1 Adapter Module (BNC) 10BASE-T hub port connectors (RJ-45)
Packaging	
BayStack AN and ANH	
Type	Tabletop/Wall-Mount/Rack-Mount
AC Voltage	100 – 240 VAC at 1.0 A maximum
Wall Receptacle	NEMA 5-15R (100 – 240 VAC; for use in North America)
DC Voltage	
Input Voltage	-48 to -60.7 VDC ($\pm 20\%$)
Input Current	1.5 A max. at -38 VDC
BayStack AN	
Size (H x W x D)	3.30 x 17.50 x 9.50 in. 8.45 x 44.45 x 23.24 cm.
Weight	12.00 lb (5.17 kg)
BayStack ANH	
Size (H x W x D)	1.75 x 17.25 x 11.25 in. 4.50 x 43.80 x 28.60 cm.
Weight	7.5 lb (3.2 kg)
Environmental and Regulatory	
Altitude	0 to 8,000 ft (0 – 2,400 m)
Humidity	20% to 80% (noncondensing)
Temperature	32° to 104°F (0° to 40°C)
Safety	UL 1950, EN60 950, CSA 22.2 950, AS/NZS 3260, TS 001
RFI/EMI	FCC Part 15, EN55022 Class A, AS/NZS 3548

System Requirements

The BayStack AN and ANH configurations described here are currently supported in software version 12.20, unless otherwise indicated in this document.

Ordering Information

BayRS software must be ordered separately for each BayStack AN or ANH. Each BayStack AN and ANH includes a manual titled *Installing the Bay Networks Access Node*. The purchase of one complete set of Bay Networks documentation (Router Installation Documents, Router Management Documents, and Technician's Interface and Hardware Documents) for each central site is recommended.

Ordering information for the BayStack AN and ANH appears in Table 5.

Table 5 | BayStack AN and ANH Ordering Information

Order Number	Description
Ethernet-Based	
AE1001007	BayStack AN with one Ethernet interface, two Synchronous interfaces, and 8 MB DRAM memory (110/220 V)
AE1001008	BayStack AN with one Ethernet interface, two Synchronous interfaces, and 16 MB DRAM memory (110/220 V)
AE1001039	BayStack DC AN with one Ethernet interface, two Synchronous interfaces, and 8 MB DRAM memory
AE1001040	BayStack DC AN with one Ethernet interface, two Synchronous interfaces, and 16 MB DRAM memory
AE1001011	BayStack ANH with 8 Ethernet hub ports (single segment), two Synchronous interfaces, and 8 MB DRAM memory (110/220 V)
AE1001012	BayStack ANH with 8 Ethernet hub ports (single segment), two Synchronous interfaces, and 16 MB DRAM memory (110/220 V)
AE1001043	BayStack DC ANH with 8 Ethernet hub ports (single segment), two Synchronous interfaces, and 8 MB DRAM memory
AE1001044	BayStack DC ANH with 8 Ethernet hub ports (single segment), two Synchronous interfaces, and 16 MB DRAM memory
AE1001015	BayStack ANH with 12 Ethernet hub ports (single segment), two Synchronous interfaces, and 8 MB DRAM memory (110/220 V)
AE1001016	BayStack ANH with 12 Ethernet hub ports (single segment), two Synchronous interfaces, and 16 MB DRAM memory (110/220 V)
Token Ring-Based	
AE1101003	BayStack AN with one Token Ring interface, two Synchronous interfaces, and 8MB DRAM memory (110/220 V)
AE1101004	BayStack AN with one Token Ring interface, two Synchronous interfaces, and 16 MB DRAM memory (110/220 V)

Table 5 | BayStack AN and ANH Ordering Information (continued)

Order Number	Description
Mixed LAN Media-Based	
AE1101007	BayStack AN with one Ethernet interface, one Token Ring interface, two Synchronous interfaces, and 8 MB DRAM memory (110/220 V)
AE1101008	BayStack AN with one Ethernet interface, one Token Ring interface, two Synchronous interfaces, and 16 MB DRAM memory (110/220 V)
BayRS	
AE0008049	BayStack AN and ANH BayRS for IP Access on 8 MB Flash
AE0008050	BayStack AN and ANH BayRS for Remote Office on 8 MB Flash
AE0008051	BayStack AN and ANH BayRS for Corporate software on 8 MB Flash
AE0008052	BayStack AN and ANH BayRS for IP Access on 16 MB Flash
AE0008053	BayStack AN and ANH BayRS for Remote Office on 16 MB Flash
AE0008054	BayStack AN and ANH BayRS for Corporate software on 16 MB Flash
Adapter Module Options	
24001	BayStack AN and 12-port BayStack ANH Third Synchronous Interface
24000	BayStack AN and 12-port BayStack ANH ISDN BRI
AE0004003	BayStack AN and 12-port BayStack ANH Second Ethernet Interface
AE0004005	8-port BayStack ANH Third Synchronous Interface
AE0004006	8-port BayStack ANH ISDN BRI Interface
AE0004007	8-port BayStack ANH Second Ethernet Interface
AE0004004	RMON Data Collection Module for BayStack AN
AE0004008	RMON Data Collection Module for 8-port BayStack ANH
AE0004011	BayStack AN and 12-port BayStack ANH 56/64 Kbps DSU/CSU Adapter Module
AE0004012	8-port BayStack ANH 56/64 Kbps DSU/CSU Adapter Module
AE0004017	8-port BayStack ANH T1/FT1 Adapter Module
AE0004016	BayStack AN and 12-port BayStack ANH T1/FT1 Adapter Module
AE0004018	AN and 12-port ANH E1/FE1 Adapter Module (RJ-45)
AE0004019	AN and 12-port ANH E1/FE1 Adapter Module (BNC)
AE0004020	8-port ANH E1/FE1 Adapter Module (RJ-45)
AE0004021	8-port ANH E1/FE1 Adapter Module (BNC)



For more sales and product information, please call **1-800-8-BAYNET**.

World Wide Web: www.baynetworks.com

Copyright © 1998 Bay Networks, Inc. All rights reserved. Bay Networks, AN, Optivity, and Quick2Config are registered trademarks, and the Bay Networks logo, BayNetworks Where Information Flows., ANH, ASN, BayRS, BayStack, BCC, DesignMan, EZ Install, EZ Internetwork, NetReporter, Optivity Analysis, Optivity Enterprise, Optivity Internetwork, Optivity Planning, Optivity Workgroup, PathMan, Remote Annex, and RouterMan are trademarks of Bay Networks, Inc. All other brand and product names are trademarks or registered trademarks of their respective holders.

United States

Bay Networks, Inc.
4401 Great America Parkway
Santa Clara, CA 95054
T. 1-800-8-BAYNET

Bay Networks, Inc.

8 Federal Street
Billerica, MA 01821-5501
T. 1-800-8-BAYNET

Europe, Middle East, and Africa

Bay Networks EMEA, S.A.
Les Cyclades – Immeuble Naxos
25 Allée Pierre Ziller
06560 Valbonne, France
T. + 33-4-92-96-69-96
F. + 33-4-92-96-69-66

Pacific Rim

Australia	T. + 61-2-9927-8888
China	T. + 8610-6515-6168
Hong Kong	T. + 852-2-539-1388
India	T. + 91-11-613-7401
Japan	T. + 81-3-5402-7001
Singapore	T. + 65-323-3522
Taiwan	T. + 886-2-27197555

Canada

T. 416-733-8348

Latin America

Brazil	T. + 55-11-5182-1244
Mexico	T. + 52-5-480-1241